

01 KF SERIES

General Information	1-2
Complete Clamp Assemblies	1-3
Application for KF Components.....	1-4
Centering Ring	1-5
Blank	1-6
Bored Blank	1-7
Socket Weld Flange (KF10~KF63)	1-7
Socket Weld Flange (KF80~KF160)	1-8
Half Nipple (Short)	1-8
Half Nipple (Long)	1-9
Half Nipple (Short for JIS Pipe)	1-9
Half Nipple (Long for JIS Pipe).....	1-10
Clamp.....	1-10
Clamp-304S.S	1-11
Spring Clamp with plastic nut.....	1-11
Spring Clamp with wing nut.....	1-12
Toggle Clamp with lock	1-12
KF Chain Clamp (KF16~KF63)	1-13
KF Chain Clamp (KF80~KF200)	1-13
Bulkhead Clamp	1-14
Nail Clamp.....	1-15
Cap.....	1-15
KF Braided Flexible Hoses	1-16
KF Flexible Hoses	1-17
KF Compressible Bellows Connections	1-18
KF Flexible Hoses Teflon Bellows.....	1-18
KF Full Nipples.....	1-19
KF 90° Elbows	1-19
KF 90° Elbows-Aluminum.....	1-20
KF Tees.....	1-20
KF Tees-Aluminum	1-21
KF Unequal Tees.....	1-21
KF 4-Way Crosses.....	1-22
KF Five-Way Crosses.....	1-22
KF Six-Way Crosses.....	1-23
KF Centering Ring	1-23
KF Centering Ring with O'Ring	1-24
KF Centering Ring with Outer Ring & O'Ring	1-25
KF Centering Ring Adaptor & O'Ring.....	1-26
KF Meshed Centering Ring	1-27
KF Overpressure Ring.....	1-28



KF SERIES

➤ General Information

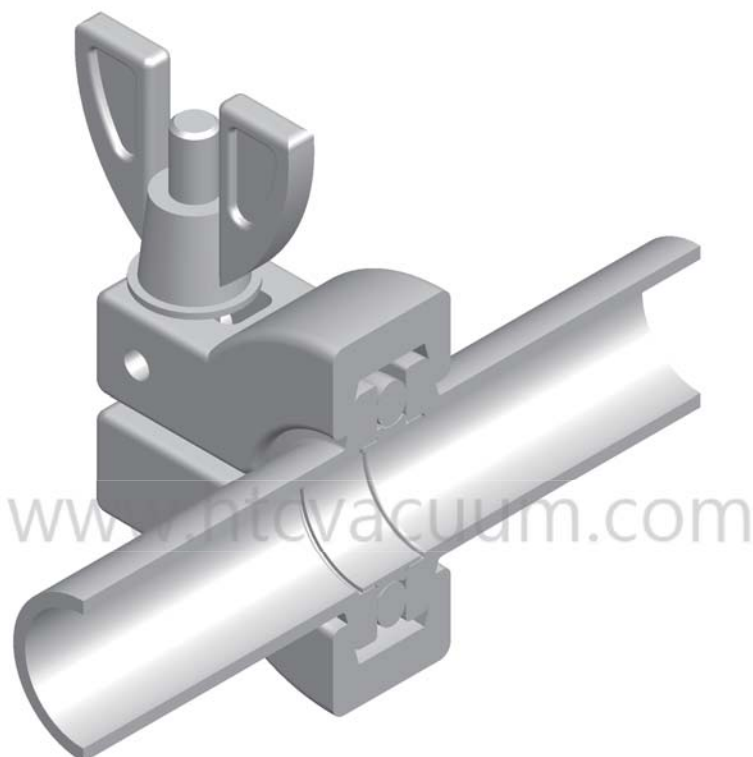

Features

- The typical KF or NW assembly consists of two identical flanges, a center-ring, and an aluminum clamp with a wingnut fastener frequently connect and disconnect without tools.
- The vacuum seal is effected by uniform application of pressure by the clamp on 15° surface of the flange.
- The mating flange surfaces compress an O’ring (held in place by metal centering ring) to generate a seal.

Specifications

- Blanks : 304 S.S. (Other material available upon request)
- Flanges : 304 S.S. (Other material available upon request)
- Fittings : 304 S.S. (Other material available upon request)
- Clamp : Aluminum, Stainless Steel
- O’ring material : Viton, NBR
- Temperature Range : 150°C (Viton) 80°C (NBR)
- Vacuum Rate : $1 \cdot 10^{-8}$ mbar
- [Larger or special size available upon request](#)

Complete Clamp Assemblies

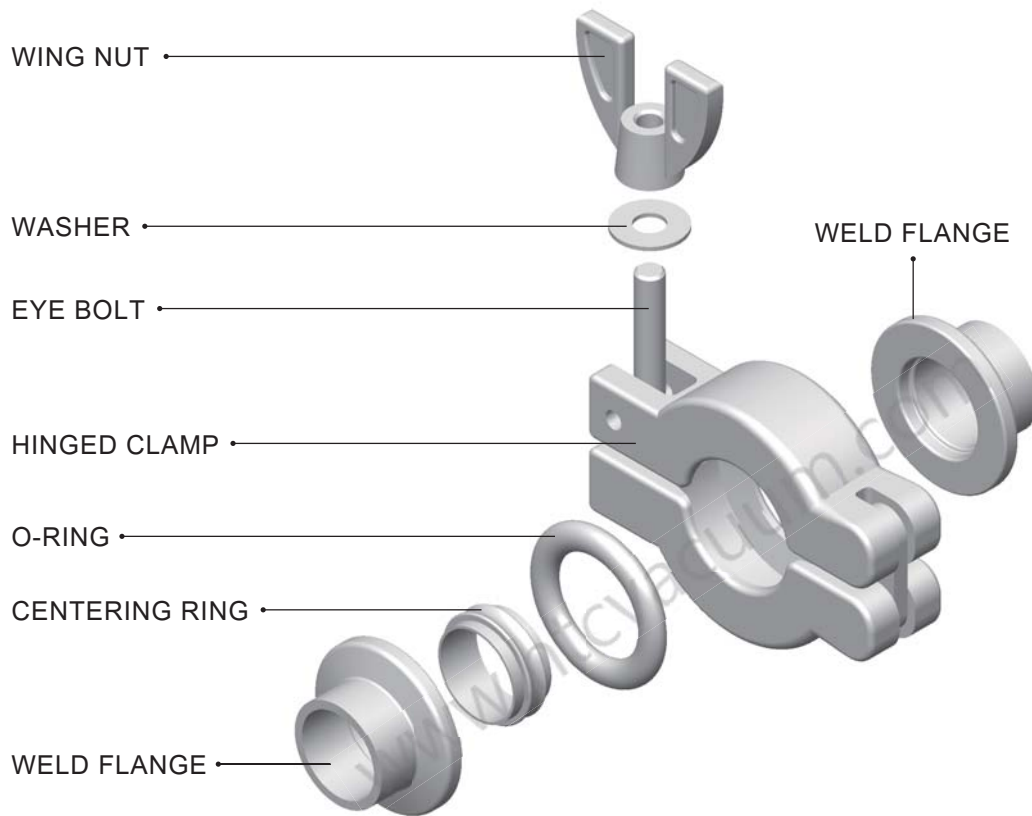

- Hinged Clamp assemblies, detailed above, are the most commonly used method for making KF-Flange vacuum seal connections. Assembly is simplified by the 360° rotatable flanges and self-centering feature of the centering ring.
- Pressure is applied uniformly around the 15° outer surface of both flanges by finger-tightening the single wingnut until the first metal-to-metal contact is made between the spacing lips of the centering ring and the inner surface of the mating flanges. This compresses the O’ring between the flanges and makes the vacuum seal.

➤ Application for KF Components

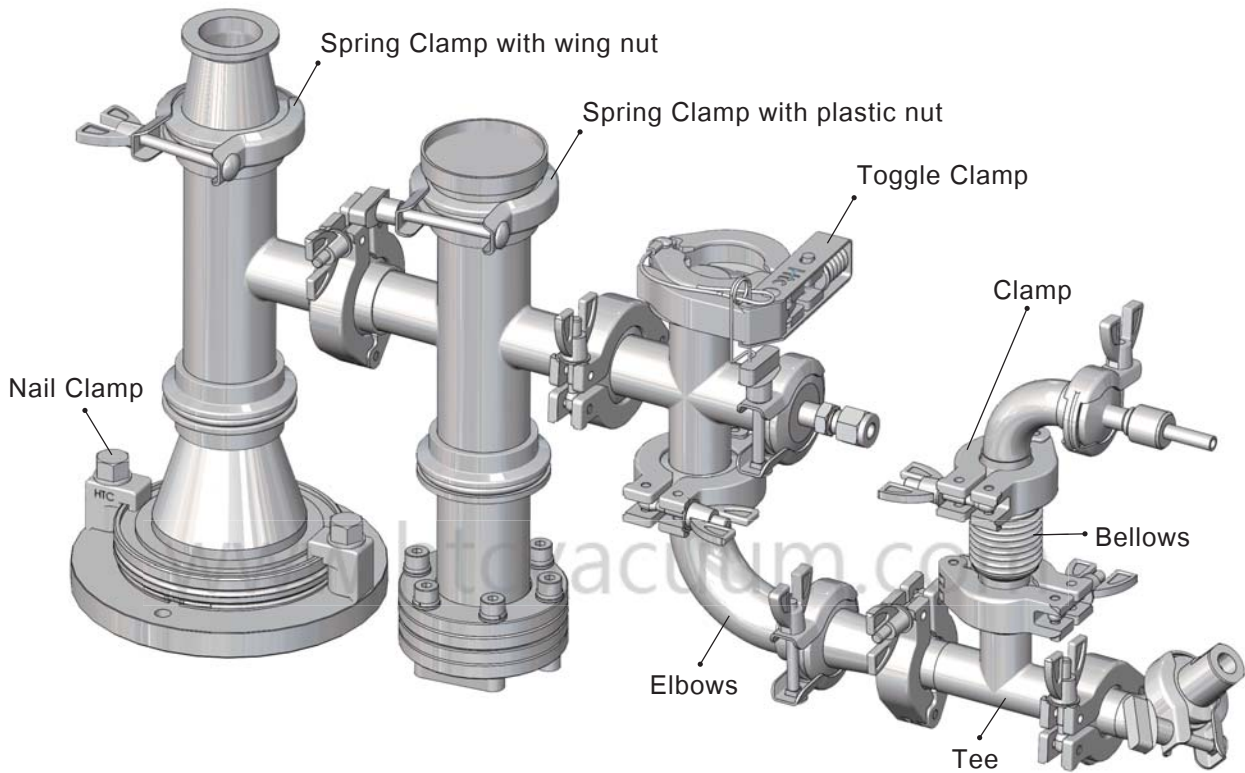

Applications for this system are as varied as the imagination can make them. Some examples are :

- ➊ Roughing and foreline plumbing for large vacuum system.
- ➋ Small system.
- ➌ System demanding frequent change.
- ➍ System demanding frequent cleaning.
- ➎ Experimental system in research laboratories.
- ➏ Teaching laboratories.

➤ Centering Ring

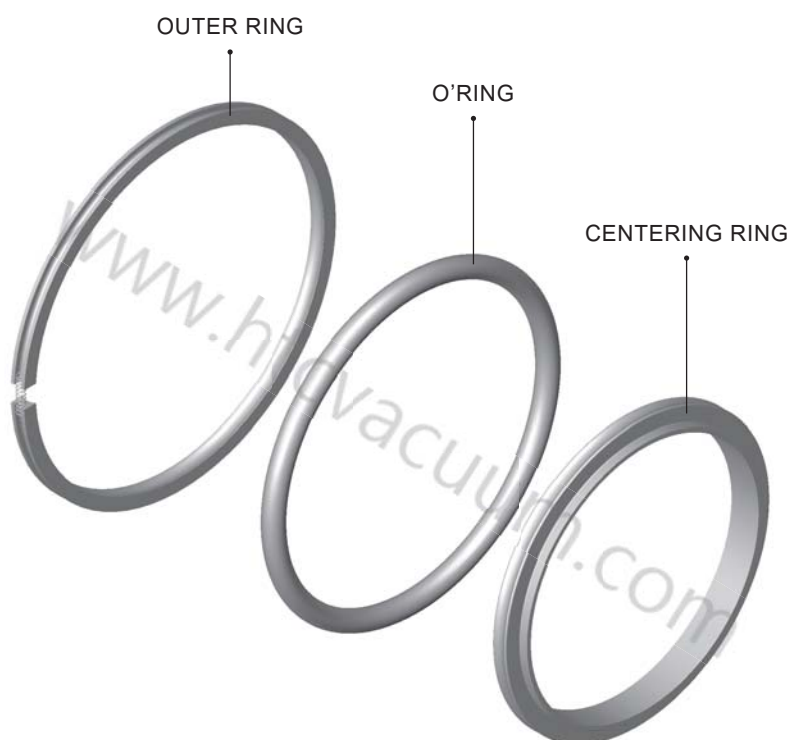

Features

- Viton O'ring bakeable to 200°C intermittently, sustained use to 150°C.
- Vacuum seal of KF-series: O'ring compression by uniform pressure application around the 15° outer flange surface.
- The vacuum seal of ISO-series is made by compressing the O'ring between the mating flanges. This done by alternately wrench-tightening opposing pairs of clamps or bolts until the first metal-to-metal contact is made between the inner surfaces of the flanges and the spacing lips of the centering ring.

Specifications

- Centering Ring : 304 S.S. (Other material available upon request)
- O'ring : Viton (Other material available upon request)
- Outer Ring : Aluminum
- Mesh : 304 S.S.
- Temperature Range : 150°C (Viton) 80°C (NBR)
- [Larger or special size available upon request](#)

Applications

- The O'ring is considered a universal sealing device. Used as static, dynamic, radial or face seals.
- Vacuum seal.



Blank

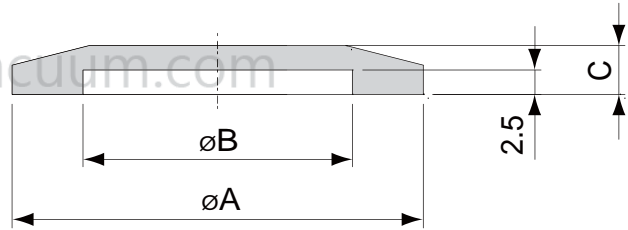

Model No.	Material	A	B	C	Parts No.
KF10BS	304 S.S.	30	12.2	5	150101003
KF16BS	304 S.S.	30	17.2	5	150102003
KF25BS	304 S.S.	40	26.2	5	150103003
KF40BS	304 S.S.	55	41.2	5	150105003
KF50BS	304 S.S.	75	52.2	5	150106003
KF63BS	304 S.S.	87	70	5	150107003
KF80BS	304 S.S.	114	83	12	150108003
KF100BS	304 S.S.	134	102	12	150109003
KF160BS	304 S.S.	190	153	12	150112003
KF10BA	Aluminum	30	12.2	5	150101001
KF16BA	Aluminum	30	17.2	5	150102001
KF25BA	Aluminum	40	26.2	5	150103001
KF40BA	Aluminum	55	41.2	5	150105001
KF50BA	Aluminum	75	52.2	5	150106001
KF63BA	Aluminum	87	70	5	150107001
KF80BA	Aluminum	114	83	12	150108001
KF100BA	Aluminum	134	102	12	150109001
KF160BA	Aluminum	190	153	12	150112001

➤ Bored Blank

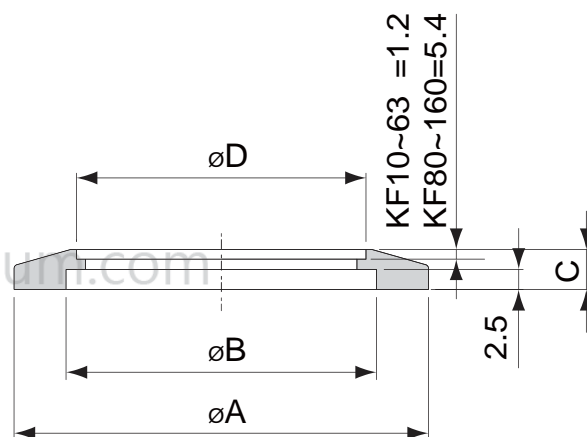

Model No.	Material	A	B	C	D	Parts No.
KF10B12	304 S.S.	30	12.2	5	12.9	150201073
KF16B19	304 S.S.	30	17.2	5	19.3	150202093
KF25B25	304 S.S.	40	26.2	5	25.7	150203113
KF40B38	304 S.S.	55	41.2	5	38.4	150205133
KF50B51	304 S.S.	75	52.2	5	51	150206143
KF63B63	304 S.S.	87	70	5	63.7	150207153
KF80B76	304 S.S.	114	83	12	76.8	150208163
KF100B102	304 S.S.	134	102	12	102.2	150209183
KF160B153	304 S.S.	190	153	12	152.9	150212203

➤ Socket Weld Flange (KF10~KF63)

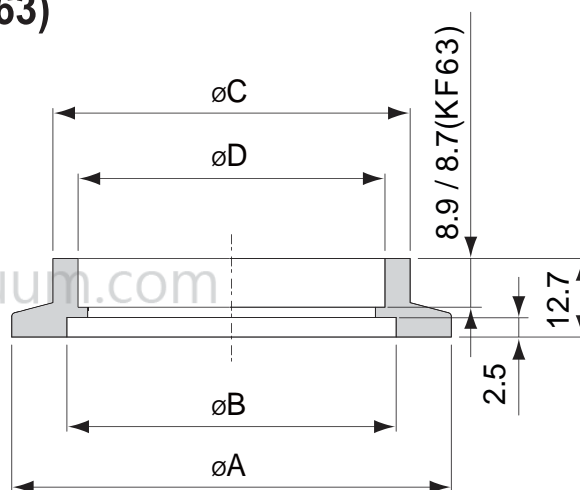

Model No.	Material	A	B	C	D	Parts No.
KF10WS	304 S.S.	30	12.2	16.5	13	150901073
KF16WS	304 S.S.	30	17.2	20.5	19.3	150902093
KF25WS	304 S.S.	40	26.2	29	25.7	150903113
KF40WS	304 S.S.	55	41.2	44.7	38.4	150905133
KF50WS	304 S.S.	75	52.2	57.4	51	150906143
KF63WS	304 S.S.	87	70	67.5	63.7	150907153



➤ Socket Weld Flange (KF80~KF160)

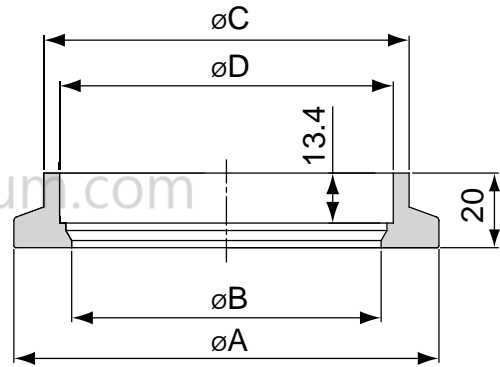

Model No.	Material	A	B	C	D	Parts No.
KF80WS	304 S.S.	114	83	98	89.5	150908AL3
KF100WS	304 S.S.	134	102	118	114.5	150909AN3
KF160WS	304 S.S.	190	153	174	165.5	150912AQ3

➤ Half Nipple (Short)

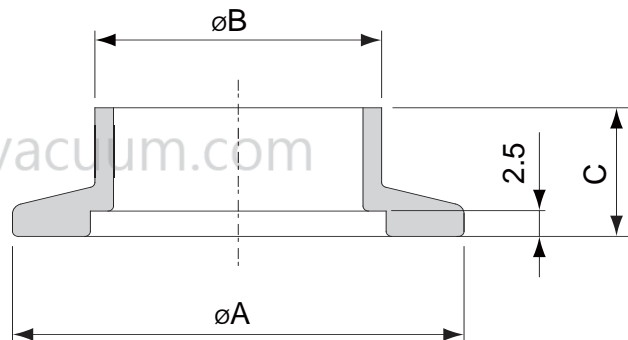

Model No.	Material	A	B	C	Available Area	Parts No.
KF10SHNSA	304 S.S.	30	12.7	12.7	U.S.A.	150301073
KF16SHNSA	304 S.S.	30	19.05	12.7	U.S.A.	150302093
KF25SHNSA	304 S.S.	40	25.4	12.7	U.S.A.	150303113
KF40SHNSA	304 S.S.	55	38.1	19.1	U.S.A.	150305133
KF50SHNSA	304 S.S.	75	50.8	19.1	U.S.A.	150306143

Special Sizes Available Upon Request

KF10SHNSE	304 S.S.	30	14	30	Europe	150501AB3
KF16SHNSE	304 S.S.	30	20	30	Europe	150502AD3
KF25SHNSE	304 S.S.	40	28	30	Europe	150503AE3
KF40SHNSE	304 S.S.	55	45	30	Europe	150505AG3
KF50SHNSE	304 S.S.	75	57	30	Europe	150506AJ3

Special Sizes Available Upon Request

KF25SHNSJ27	304 S.S.	40	27.2	20	Japan	150703AE3
KF40SHNSJ42	304 S.S.	55	42.7	20	Japan	150705AG3
KF50SHNSJ60	304 S.S.	75	60.5	20	Japan	150706AJ3



➤ Half Nipple (Long)

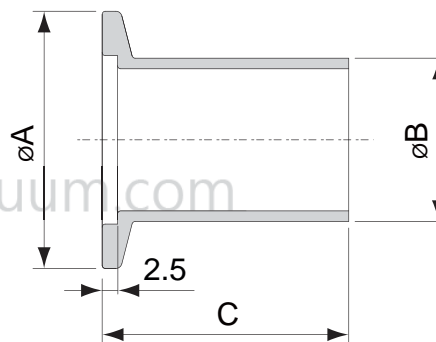

Model No.	Material	A	B	C	Available Area	Parts No.
KF10LHNSA	304 S.S.	30	12.7	40	U.S.A.	150401073
KF16LHNSA	304 S.S.	30	19.05	40	U.S.A.	150402093
KF25LHNSA	304 S.S.	40	25.4	40	U.S.A.	150403113
KF40LHNSA	304 S.S.	55	38.1	40	U.S.A.	150405133
KF50LHNSA	304 S.S.	75	50.8	40	U.S.A.	150406143
KF10LHNAA	Aluminum	30	12.7	40	U.S.A.	150401071
KF16LHNAA	Aluminum	30	19.05	40	U.S.A.	150402091
KF25LHNAA	Aluminum	40	25.4	40	U.S.A.	150403111
KF40LHNAA	Aluminum	55	38.1	40	U.S.A.	150405131
KF50LHNAA	Aluminum	75	50.8	40	U.S.A.	150406141
Special Sizes Available Upon Request						
KF10LHNSE	304 S.S.	30	14	70	Europe	150601AB3
KF16LHNSE	304 S.S.	30	20	70	Europe	150602AD3
KF25LHNSE	304 S.S.	40	28	70	Europe	150603AE3
KF40LHNSE	304 S.S.	55	45	70	Europe	150605AG3
KF50LHNSE	304 S.S.	75	57	70	Europe	150606AJ3
KF50LHNSJ	304 S.S.	75	60.5	40	Japan	150806AJ3

➤ Half Nipple (Short for JIS Pipe)

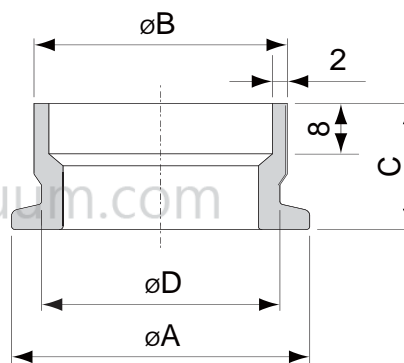

Model No.	Material	A	B	C	D	Available Area	Parts No.
KF25SHNSJ34	304 S.S.	40	34	20	32	Japan	150703AF3
KF40SHNSJ48	304 S.S.	55	48.6	20	45	Japan	150705AH3



➔ Half Nipple (Long for JIS Pipe)

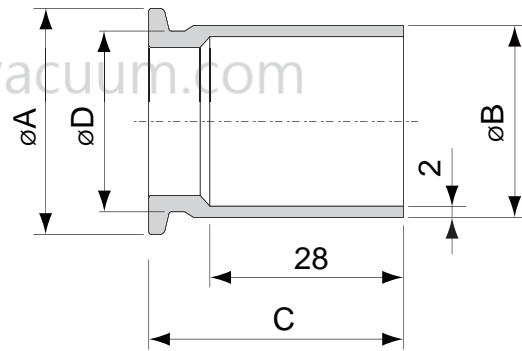

Model No.	Material	A	B	C	D	Available Area	Parts No.
KF25LHNSJ	304 S.S.	40	34	40	32	Japan	150803AF3
KF40LHNSJ	304 S.S.	55	48.6	40	45	Japan	150805AH3

➔ Clamp

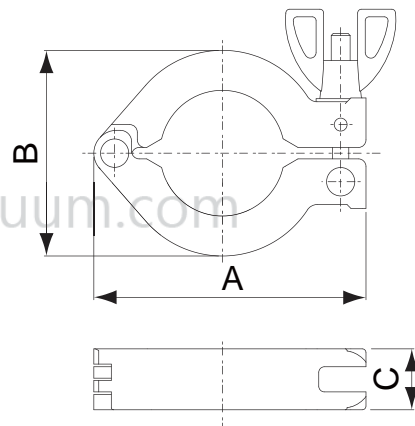

Model No.	Material	A	B	C	Surface Treatment	Parts No.
KF16CLA	Aluminum	63	42.5	16		21010511
KF25CLA	Aluminum	72	54	16		21010611
KF40CLA	Aluminum	90	70	16		21010811
KF50CLA	Aluminum	114	90	20		21010911
KF16CLA-NP	Aluminum	63	42.5	16	Nickel Plating	21010521
KF25CLA-NP	Aluminum	72	54	16	Nickel Plating	21010621
KF40CLA-NP	Aluminum	90	70	16	Nickel Plating	21010821
KF50CLA-NP	Aluminum	114	90	20	Nickel Plating	21010921

➤ Clamp-304S.S.

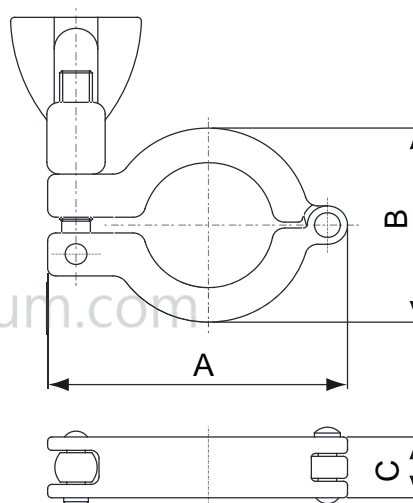

Model No.	Material	A	B	C	Parts No.
KF16CL-304	304 S.S.	59.5	36	15.5	21010541
KF25CL-304	304 S.S.	73.5	49	15.5	21010641
KF40CL-304	304 S.S.	90	64	16	21010841
KF50CL-304	304 S.S.	112	82	20	21010941

➤ Spring Clamp

With plastic nut

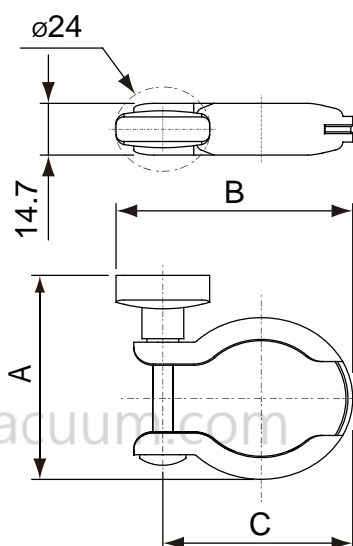

Features

- Light, low cost and without assembly space limit.
- Could change fasten nut on request.

Specifications

- Material :
 - a. Body : 304S.S.
 - b. Bolt : 304S.S.
 - c. Plastic Nut : ABS.

Model No.	A	B	C	Parts No.
KF10SCLS	50	52	40	21090542
KF16SCLS	50	52	40	21090542
KF25SCLS	58	59	48	21090642
KF40SCLS	72	73	62	21090842

Spring Clamp

With wing nut

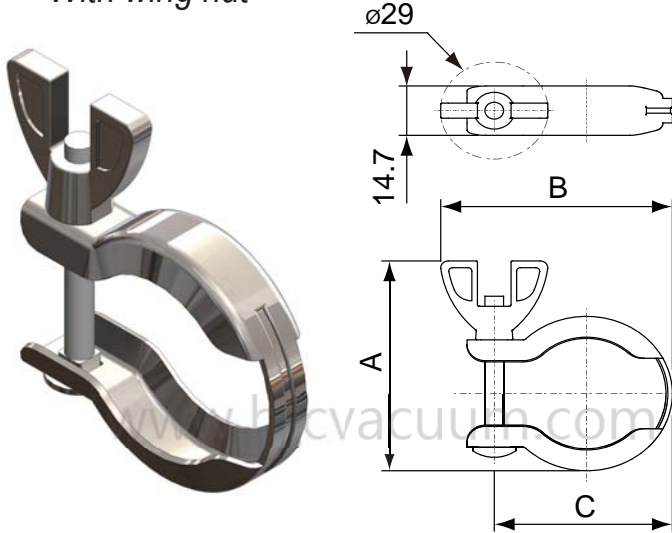

Features

- Light, low cost and without assembly space limit.
- Could change fasten nut on request.

Specifications

- Material :
 - a. Body : 304S.S.
 - b. Bolt : 304S.S.
 - c. Wing Nut : 304S.S.

Model No.	A	B	C	Parts No.
KF10SCLSW	55	54	40	21090542S
KF16SCLSW	55	54	40	21090542S
KF25SCLSW	63	62	48	21090642S
KF40SCLSW	77	76	62	21090842S

Toggle Clamp

With Lock

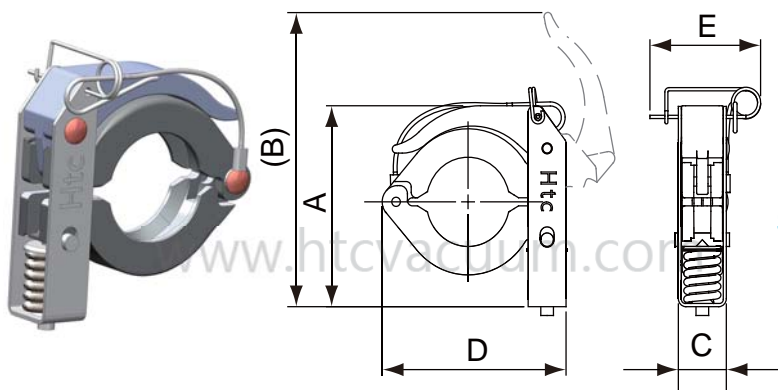

Features

- A lock pin can be inserted to prevent accidental release of the toggle lever.
- Easy for quick installation and uninstall.
- Self-adjusting clamp without manual over tightening.

Specifications

- Material :
 - a. Body : Aluminum
 - b. Pin : 304S.S.
 - c. Spring seat : 304S.S.

Model No.	A	B	C	D	E	Parts No.
KF16TCLA	66	(97)	20	63	43	2107051A
KF25TCLA	75	(106)	20	74	43	2107061A
KF40TCLA	85	(123)	20	90	43	2107081A
KF50TCLA	118	(165)	23	115	43	2107091A



➤ KF Chain Clamps (KF16~KF63)

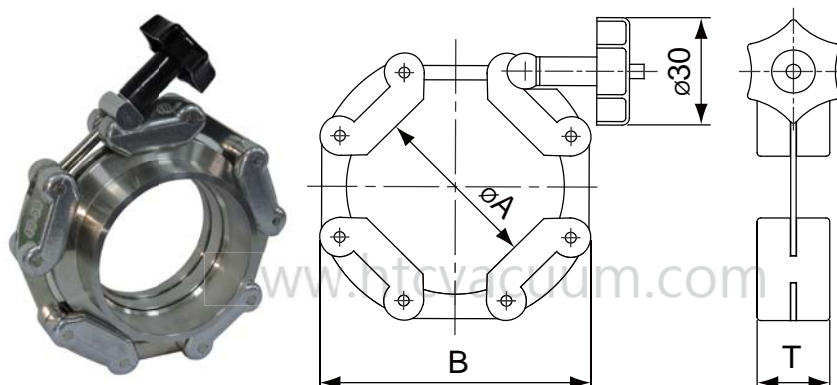

Features

- Links constructed of pressure die-cast aluminum alloy.
- Quick opening and closing of clamp.
- Clamp design allows for high-sealing forces.

Model No.	Flange size	Material	A	B	T	Part No.
CC-N-16	KF10/KF16	Block Aluminum	22	56	20.3	21020511
CC-N-25	KF25	Block Aluminum	32	66	20.3	21020611
CC-N-40	KF40	Block Aluminum	46	80	20.3	21020811
CC-N-50	KF50	Block Aluminum	69	100	20.3	21020911
CC-N-63	KF63	Block Aluminum	78	112	20.3	21021011

➤ KF Chain Clamps (KF80~KF200)

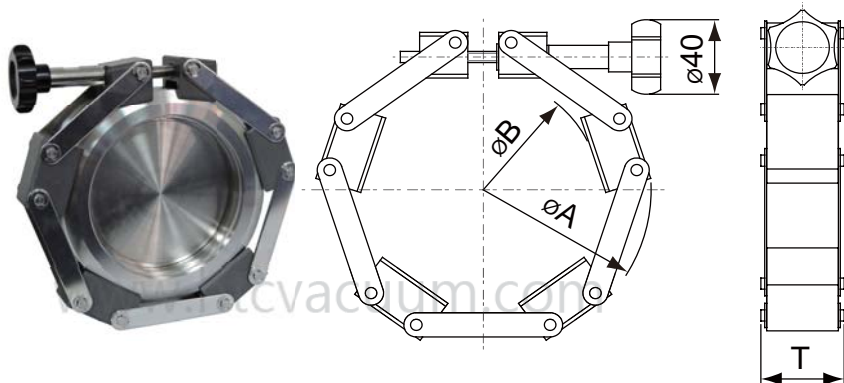

Features

- Links constructed of pressure die-cast aluminum alloy.
- Pins & Links constructed of stainless steel.
- Quick opening and closing of clamp.
- Clamp design allows for high-sealing forces.

Model No.	Flange size	Material	A	B	T	Part No.
CC-N-80	KF80	Block Aluminum	165	99.8	37.1	21021111
CC-N-100	KF100	Block Aluminum	185	120.7	37.1	21021211
CC-N-125	KF125	Block Aluminum	210	149.5	37.1	21021311
CC-N-160	KF160	Block Aluminum	235	177.5	37.1	21021511
CC-N-200	KF200	Block Aluminum	300	240.3	37.1	21021611

➔ Bulkhead Clamp

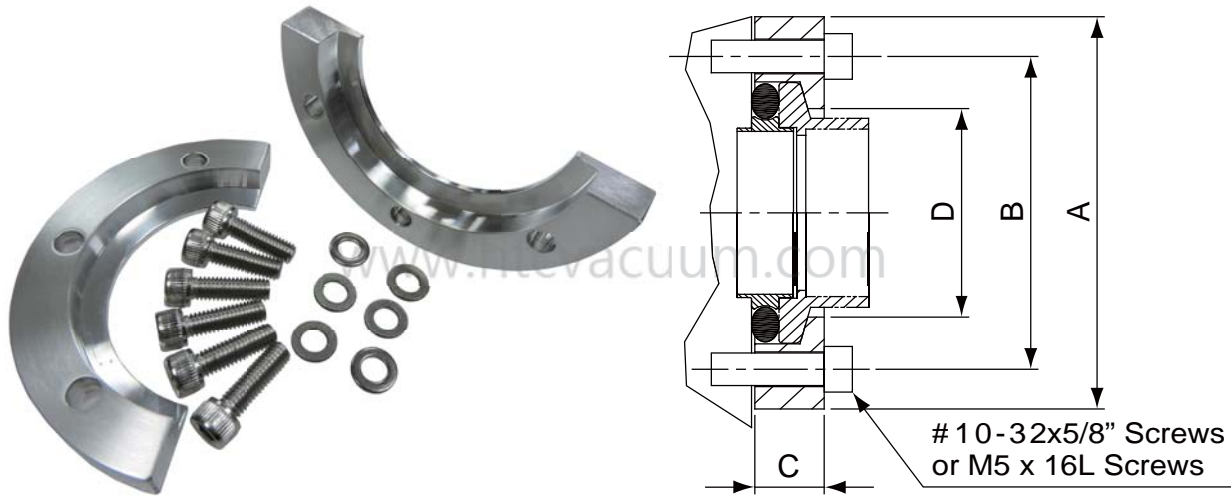

These aluminum Bulkhead Clamps are used to fasten KF flanges to vacuum process systems. Adapts to baseplates or flat walls with six or eight #10-32 UNF (or M5x16L) threaded bolt holes on the mounting surface. The clamp is aligned with the standard KF seal assembly (a KF flange and a centering ring with O-ring) and fastened to the mating bolt holes to form the vacuum seal between the connecting pairs.

The standard sizes for Bulkhead Clamps are KF-10, KF-16, KF-25, KF-40, and KF-50.

Model No.	Material	A	B	C	D	Bolt Size* No	Parts No.
NW-16-BCP	A6061-T6	50.8	38.1	9.17	22.86	#10-32x5/8" L*6	ZCP006A0220100
NW-25-BCP	A6061-T6	60.2	48.01	9.83	32	#10-32x5/8" L*6	ZCP006A0220200
NW-40-BCP	A6061-T6	74.68	61.98	9.3	46.22	#10-32x5/8" L*6	ZCP006A0220300
NW-50-BCP	A6061-T6	95.25	82.6	10.26	59.69	#10-32x5/8" L*8	ZCP006A0220400
NW-16-BCP-M	A6061-T6	50.8	38.1	9.17	22.86	M5x16L*6	ZCP274A0060100
NW-25-BCP-M	A6061-T6	60.2	48.01	9.83	32	M5x16L*6	ZCP274A0060200
NW-40-BCP-M	A6061-T6	74.68	61.98	9.3	46.22	M5x16L*6	XCB069A0150300
NW-50-BCP-M	A6061-T6	95.25	82.6	10.26	59.69	M5x16L*8	ZCP274A0060300

The part numbers in the table include the bolts.

➤ Nail Clamp

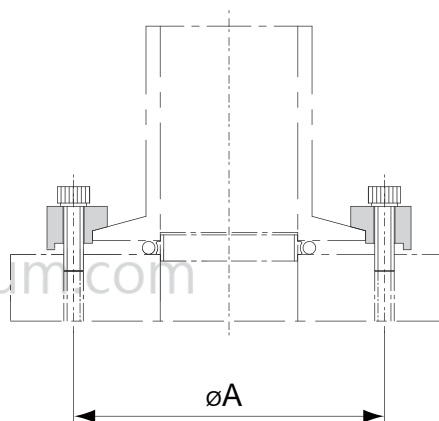

Model No.	Material	A	Bolt Size	Fits Size	Quantity	Parts No.
KF-NCA	Aluminum	43	M6*20L	KF10	3	2103A111
KF-NCA	Aluminum	43	M6*20L	KF16	3	2103A111
KF-NCA	Aluminum	53	M6*20L	KF25	4	2103A111
KF-NCA	Aluminum	68	M6*20L	KF40	4	2103A111
KF-NCA	Aluminum	88	M6*20L	KF50	6	2103A111

➤ Cap

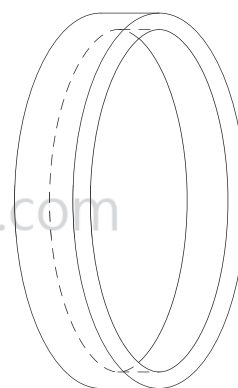

Model No.	Material	A	Parts No.
KF10CAP	Polyethylene	KF10	5085DG
KF16CAP	Polyethylene	KF16	5085DG
KF25CAP	Polyethylene	KF25	5085DY
KF40CAP	Polyethylene	KF40	5085EJ
KF50CAP	Polyethylene	KF50	5085FD
KF63CAP	Polyethylene	KF63	5085FX
KF80CAP	Polyethylene	KF80	5085H3
KF100CAP	Polyethylene	KF100	5085HX



➔ **KF Braided Flexible Hoses**

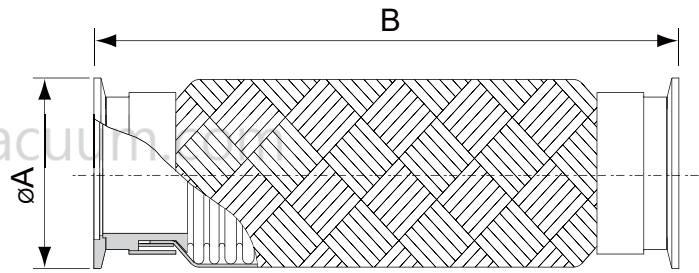

Model No.	Material	A	B	Parts No.
KF16BFX250	304 S.S.	30	250	40210550250AA
KF16BFX500	304 S.S.	30	500	40210550500AA
KF16BFX750	304 S.S.	30	750	40210550750AA
KF16BFX1000	304 S.S.	30	1000	40210551000AA
KF25BFX250	304 S.S.	40	250	40210560250AA
KF25BFX500	304 S.S.	40	500	40210560500AA
KF25BFX750	304 S.S.	40	750	40210560750AA
KF25BFX1000	304 S.S.	40	1000	40210561000AA
KF40BFX250	304 S.S.	55	250	40210570250AA
KF40BFX500	304 S.S.	55	500	40210570500AA
KF40BFX750	304 S.S.	55	750	40210570750AA
KF40BFX1000	304 S.S.	55	1000	40210571000AA
KF50BFX250	304 S.S.	75	250	40210580250AA
KF50BFX500	304 S.S.	75	500	40210580500AA
KF50BFX750	304 S.S.	75	750	40210580750AA
KF50BFX1000	304 S.S.	75	1000	40210581000AA

➔ KF Flexible Hoses

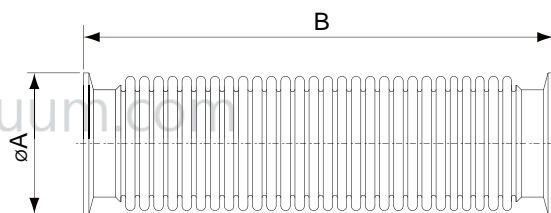

Model No.	Material	A	B	Parts No.
KF16FX250	304 S.S.	30	250	40010550250AA
KF16FX500	304 S.S.	30	500	40010550500AA
KF16FX750	304 S.S.	30	750	40010550750AA
KF16FX1000	304 S.S.	30	1000	40010551000AA
KF25FX250	304 S.S.	40	250	40010560250AA
KF25FX500	304 S.S.	40	500	40010560500AA
KF25FX750	304 S.S.	40	750	40010560750AA
KF25FX1000	304 S.S.	40	1000	40010561000AA
KF40FX250	304 S.S.	55	250	40010570250AA
KF40FX500	304 S.S.	55	500	40010570500AA
KF40FX750	304 S.S.	55	750	40010570750AA
KF40FX1000	304 S.S.	55	1000	40010571000AA
KF50FX250	304 S.S.	75	250	40010580250AA
KF50FX500	304 S.S.	75	500	40010580500AA
KF50FX750	304 S.S.	75	750	40010580750AA
KF50FX1000	304 S.S.	75	1000	40010581000AA

➔ KF Compressible Bellows Connections

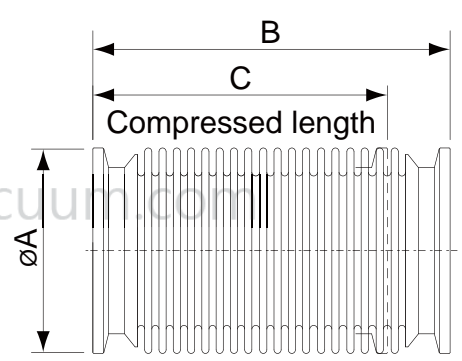

Model No.	Material	A	B	C	Parts No.
KF10FXC100	304 S.S.	30	100	80	40310410100AA
KF16FXC100	304 S.S.	30	100	80	40310430100AA
KF25FXC100	304 S.S.	40	100	80	40310440100AA
KF40FXC100	304 S.S.	55	100	80	40310450100AA
KF50FXC100	304 S.S.	75	100	80	40310460100AA

➔ KF Flexible Hoses

Teflon Bellows

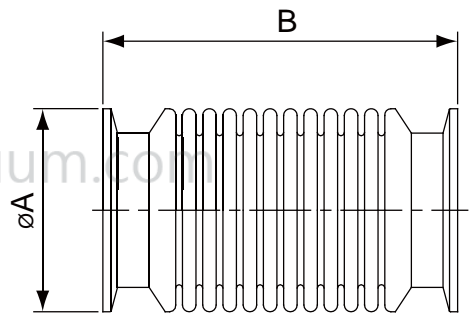

Model No.	Material	A	B	Parts No.
KF40FX100T	TEFLON	55	100	42001670100AA
KF50FX100T	TEFLON	75	100	42001680100AA

Teflon bellows with Metal flange frame

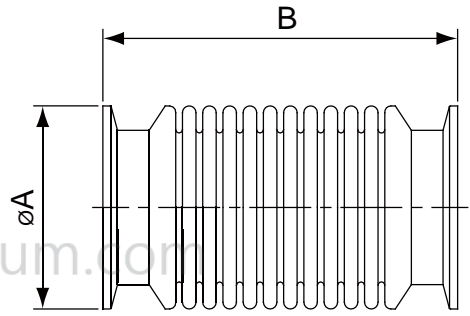

Model No.	Material	A	B	Parts No.
KF40FX100TS	TEFLON	55	100	42021670100AA
KF50FX100TS	TEFLON	75	100	42021680100AA



➤ KF Full Nipples

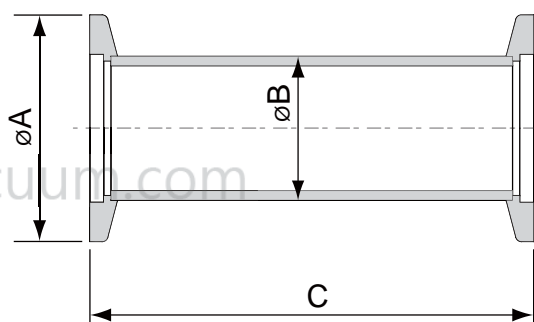

Model No.	Material	A	B	C	Parts No.
KF16N80	304 S.S.	30	19.05	80	160110210200804
KF25N100	304 S.S.	40	25.4	100	160110310301004
KF40N130	304 S.S.	55	38.1	130	160110510501304
KF50N140	304 S.S.	75	50.8	140	160110610601404

* Part number plus "K" for sand blasting surface

* Part number plus "L" for polished surface

➤ KF 90° Elbows

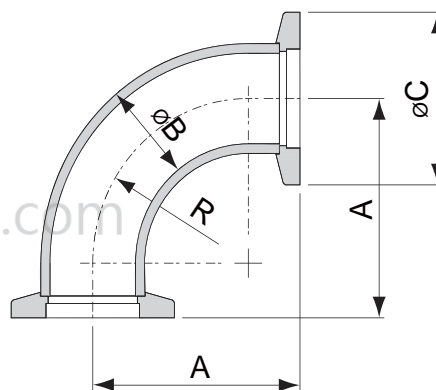

Model No.	Material	A	B	C	D	Available Area	Parts No.
KF16EL90A	304 S.S.	38.3	19.05	30	28.6	U.S.A.	16031021024
KF25EL90A	304 S.S.	56.2	25.4	40	38.1	U.S.A.	16031031034
KF40EL90A	304 S.S.	78.4	38.1	55	57.2	U.S.A.	16031051054
KF50EL90A	304 S.S.	107	50.8	75	76.2	U.S.A.	16031061064
KF16EL90E	304 S.S.	40	19.05	30	28.6	Europe	16041021024
KF25EL90E	304 S.S.	50.8	25.4	40	38.1	Europe	16041031034
KF40EL90E	304 S.S.	65	38.1	55	57.2	Europe	16041051054
KF50EL90E	304 S.S.	80	50.8	75	76.2	Europe	16041061064

* Special Size Available Upon Request.

* Part number plus "K" for sand blasting surface

* Part number plus "L" for polished surface



➔ **KF 90° Elbows-Aluminum**

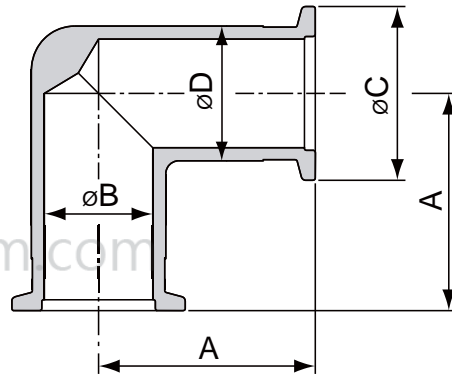

Model No.	Material	A	B	C	D	Available Area	Parts No.
KF16EL90AL	AL6082	40	16	30	21	Europe	16041021029S
KF25EL90AL	AL6082	50	25	40	31	Europe	16041031039S
KF40EL90AL	AL6082	65	39	55	45	Europe	16041051059S

➔ **KF Tees**

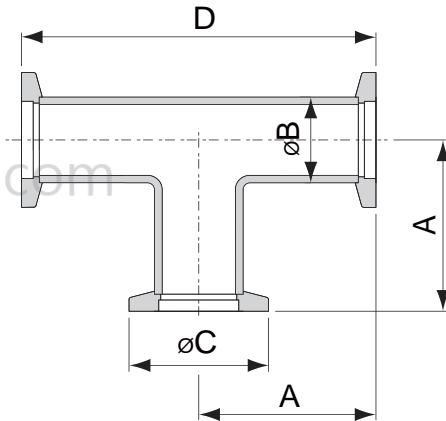

Model No.	Material	A	B	C	D	Available Area	Parts No.
KF16TA	304 S.S.	38.3	19.05	30	76.6	U.S.A.	16151021024
KF25TA	304 S.S.	51.4	25.4	40	102.8	U.S.A.	16151031034
KF40TA	304 S.S.	61	38.1	55	122	U.S.A.	16151051054
KF50TA	304 S.S.	80	50.8	75	160	U.S.A.	16151061064
KF16TE	304 S.S.	40	19.05	30	80	Europe	16161021024
KF25TE	304 S.S.	50	25.4	40	100	Europe	16161031034
KF40TE	304 S.S.	65	38.1	55	130	Europe	16161051054
KF50TE	304 S.S.	70	50.8	75	140	Europe	16161061064

- * Special Size Available Upon Request.
- * Part number plus "K" for sand blasting surface
- * Part number plus "L" for polished surface



➤ KF Tees-Aluminum

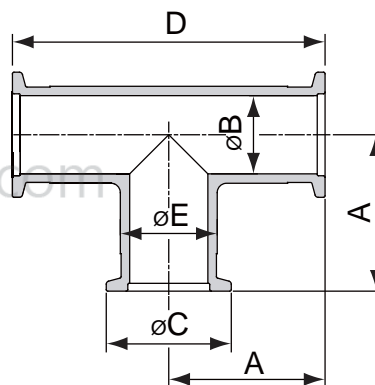

Model No.	Material	A	B	C	D	E	Available Area	Parts No.
KF16TEAL	AL6082	40	16	30	80	21	Europe	16161021029S
KF25TEAL	AL6082	50	25	40	100	31	Europe	16161031039S
KF40TEAL	AL6082	65	39	55	130	45	Europe	16161051059S

➤ KF Unequal Tees

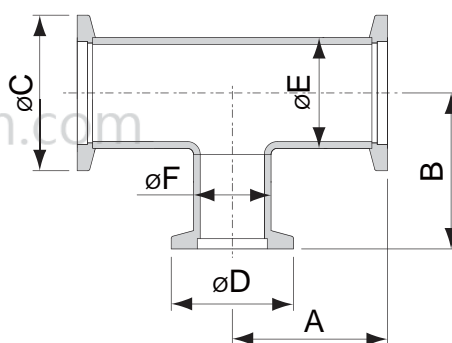

Model No.	Material	A	B	C	D	E	F	Available Area	Parts No.
KF25UT16A	304 S.S.	52	37.5	40	30	25.4	19.05	U.S.A.	16171031024
KF40UT16A	304 S.S.	61	52	55	30	38.1	19.05	U.S.A.	16171051024
KF40UT25A	304 S.S.	61	57.8	55	40	38.1	25.4	U.S.A.	16171051034
KF50UT16A	304 S.S.	80	58.2	75	30	50.8	19.05	U.S.A.	16171061024
KF50UT25A	304 S.S.	80	64.1	75	40	50.8	25.4	U.S.A.	16171061034
KF50UT40A	304 S.S.	80	67.3	75	55	50.8	38.1	U.S.A.	16171061054
KF25UT16E	304 S.S.	50	40	40	30	25.4	19.05	Europe	16181031024
KF40UT16E	304 S.S.	65	40	55	30	38.1	19.05	Europe	16181051024
KF40UT25E	304 S.S.	65	50	55	40	38.1	25.4	Europe	16181051034
KF50UT16E	304 S.S.	70	50	75	30	50.8	19.05	Europe	16181061024
KF50UT25E	304 S.S.	70	65	75	40	50.8	25.4	Europe	16181061034
KF50UT40E	304 S.S.	70	65	75	55	50.8	38.10	Europe	16181061054

* Special Size Available Upon Request.

* Part number plus "K" for sand blasting surface

* Part number plus "L" for polished surface



➔ **KF 4-Way Crosses**

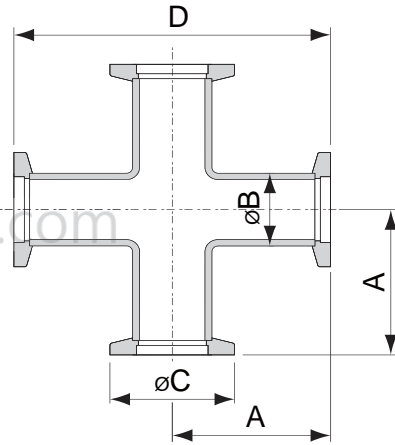

Model No.	Material	A	B	C	D	Available Area	Parts No.
KF16XA	304 S.S.	38.3	19.05	30	76.6	U.S.A.	16191021024
KF25XA	304 S.S.	51.4	25.4	40	102.8	U.S.A.	16191031034
KF40XA	304 S.S.	61	38.1	55	122	U.S.A.	16191051054
KF50XA	304 S.S.	80	50.8	75	160	U.S.A.	16191061064
KF16XE	304 S.S.	40	19.05	30	80	Europe	16201021024
KF25XE	304 S.S.	50	25.4	40	100	Europe	16201031034
KF40XE	304 S.S.	65	38.1	55	130	Europe	16201051054
KF50XE	304 S.S.	70	50.8	75	140	Europe	16201061064

- * Special Size Available Upon Request.
- * Part number plus "K" for sand blasting surface
- * Part number plus "L" for polished surface

➔ **KF Five-Way Crosses**

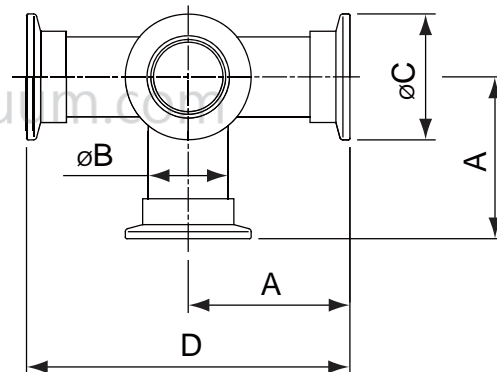

Model No.	Material	A	B	C	D	Parts No.
KF16FXA	304 S.S.	38.3	19.05	30	76.6	16261021024
KF25FXA	304 S.S.	51.4	25.4	40	102.8	16261031034
KF40FXA	304 S.S.	61	38.1	55	122	16261051054
KF50FXA	304 S.S.	80	50.8	75	160	16261061064

- * Part number plus "K" for sand blasting surface
- * Part number plus "L" for polished surface



➤ KF Six-Way Crosses

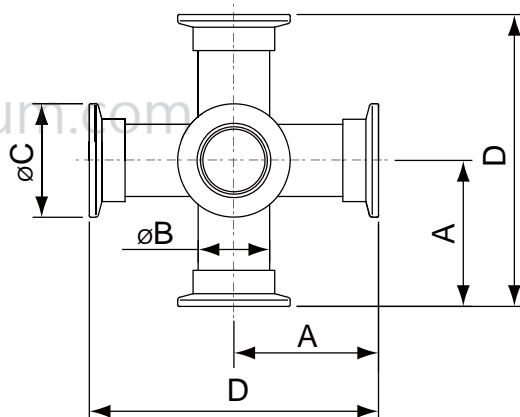

Model No.	Material	A	B	C	D	Parts No.
KF16SXA	304 S.S.	38.3	19.05	30	76.6	16281021024
KF25SXA	304 S.S.	51.4	25.4	40	102.8	16281031034
KF40SXA	304 S.S.	61	38.1	55	122	16281051054
KF50SXA	304 S.S.	80	50.8	75	160	16281061064

* Part number plus "K" for sand blasting surface

* Part number plus "L" for polished surface

➤ KF Centering Ring

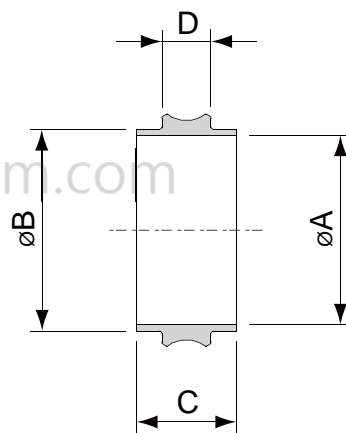

Model No.	Material	A	B	C	D	Parts No.
KF10CRS	304 S.S.	10	12	8	3.9	180003410
KF16CRS	304 S.S.	16	17	8	3.9	180005410
KF25CRS	304 S.S.	25	26	8	3.9	180006410
KF40CRS	304 S.S.	40	41	8	3.9	180008410
KF50CRS	304 S.S.	50	52	8	3.9	180009410
KF10CRA	Al	10	12	8	3.9	180003110
KF16CRA	Al	16	17	8	3.9	180005110
KF25CRA	Al	25	26	8	3.9	180006110
KF40CRA	Al	40	41	8	3.9	180008110
KF50CRA	Al	50	52	8	3.9	180009110



➔ KF Centering Ring with O'Ring

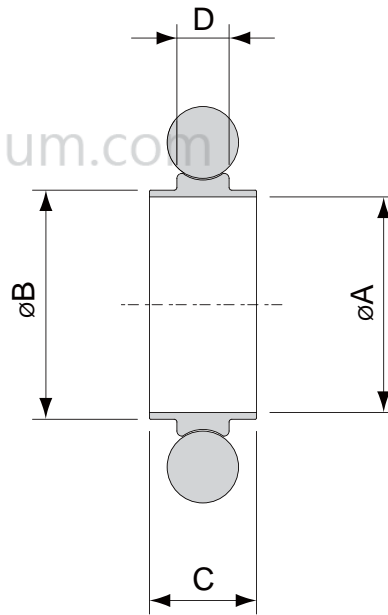

Model No.	Material C/R	Material O'Ring	A	B	C	D	O'Ring Size	Parts No.
KF10CRVS	304 S.S.	Viton	10	12	8	3.9	AS-311	180103411
KF16CRVS	304 S.S.	Viton	16	17	8	3.9	AS-314	180105411
KF25CRVS	304 S.S.	Viton	25	26	8	3.9	AS-320	180106411
KF40CRVS	304 S.S.	Viton	40	41	8	3.9	AS-326	180108411
KF50CRVS	304 S.S.	Viton	50	52	8	3.9	AS-330	180109411
KF10CRVA	Al	Viton	10	12	8	3.9	AS-311	180103111
KF16CRVA	Al	Viton	16	17	8	3.9	AS-314	180105111
KF25CRVA	Al	Viton	25	26	8	3.9	AS-320	180106111
KF40CRVA	Al	Viton	40	41	8	3.9	AS-326	180108111
KF50CRVA	Al	Viton	50	52	8	3.9	AS-330	180109111
KF10CRNS	304 S.S.	NBR	10	12	8	3.9	AS-311	180303412
KF16CRNS	304 S.S.	NBR	16	17	8	3.9	AS-314	180305412
KF25CRNS	304 S.S.	NBR	25	26	8	3.9	AS-320	180306412
KF40CRNS	304 S.S.	NBR	40	41	8	3.9	AS-326	180308412
KF50CRNS	304 S.S.	NBR	50	52	8	3.9	AS-330	180309412
KF10CRNA	Al	NBR	10	12	8	3.9	AS-311	180303112
KF16CRNA	Al	NBR	16	17	8	3.9	AS-314	180305112
KF25CRNA	Al	NBR	25	26	8	3.9	AS-320	180306112
KF40CRNA	Al	NBR	40	41	8	3.9	AS-326	180308112
KF50CRNA	Al	NBR	50	52	8	3.9	AS-330	180309112

* O'Ring color for NBR material is black, brown is available upon request.

* O'Ring color for Viton material is brown, black is available upon request.



➤ KF Centering Ring with Outer Ring & O'Ring

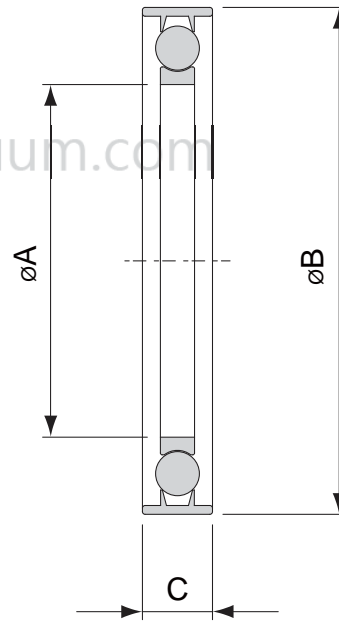

Model No.	Material C/R	Material O/R	Material O'Ring	A	B	C	O'Ring Size	Parts No.
KF16OCRVS	304 S.S.	Al	Viton	16	32.5	8	5018	181105421
KF25OCRVS	304 S.S.	Al	Viton	25	42.5	8	5028	181106421
KF40OCRVS	304 S.S.	Al	Viton	40	57.5	8	5042	181108421
KF50OCRVS	304 S.S.	Al	Viton	50	77.5	8	AS-330	181109421
KF16OCR-316	316 S.S.	Al	Viton	16	32.5	8	5018	181105621
KF25OCR-316	316 S.S.	Al	Viton	25	42.5	8	5028	181106621
KF40OCR-316	316 S.S.	Al	Viton	40	57.5	8	5042	181108621
KF50OCR-316	316 S.S.	Al	Viton	50	77.5	8	AS-330	181109621

* O'Ring color is brown, black is available upon request.

➔ KF Centering Ring Adaptor & O'Ring

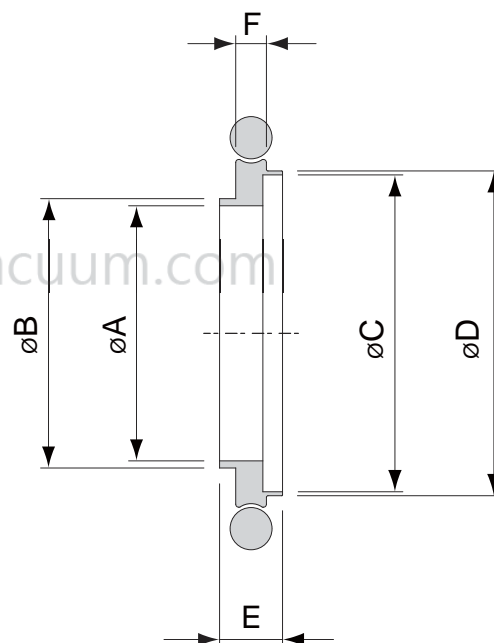

Model No.	Material C/R	Material O'Ring	A	B	C	D	E	F	O'Ring Size	Parts No.
KF10CR16VS	304 S.S.	Viton	10	12	16	17	8	3.9	AS-314	19011A411
KF20CR25VS	304 S.S.	Viton	20	22	25	26	8	3.9	AS-320	19011B411
KF32CR40VS	304 S.S.	Viton	32	34	40	41	8	3.9	AS-326	19011C411
KF10CR16VA	Al	Viton	10	12	16	17	8	3.9	AS-314	19011A111
KF20CR25VA	Al	Viton	20	22	25	26	8	3.9	AS-320	19011B111
KF32CR40VA	Al	Viton	32	34	40	41	8	3.9	AS-326	19011C111
KF10CR16NS	304 S.S.	NBR	10	12	16	17	8	3.9	AS-314	19031A412
KF20CR25NS	304 S.S.	NBR	20	22	25	26	8	3.9	AS-320	19031B412
KF32CR40NS	304 S.S.	NBR	32	34	40	41	8	3.9	AS-326	19031C412
KF10CR16NA	Al	NBR	10	12	16	17	8	3.9	AS-314	19031A112
KF20CR25NA	Al	NBR	20	22	25	26	8	3.9	AS-320	19031B112
KF32CR40NA	Al	NBR	32	34	40	41	8	3.9	AS-326	19031C112

* O'Ring color for NBR material is black, brown is available upon request.

* O'Ring color for Viton material is brown, black is available upon request.

➤ KF Meshed Centering Ring

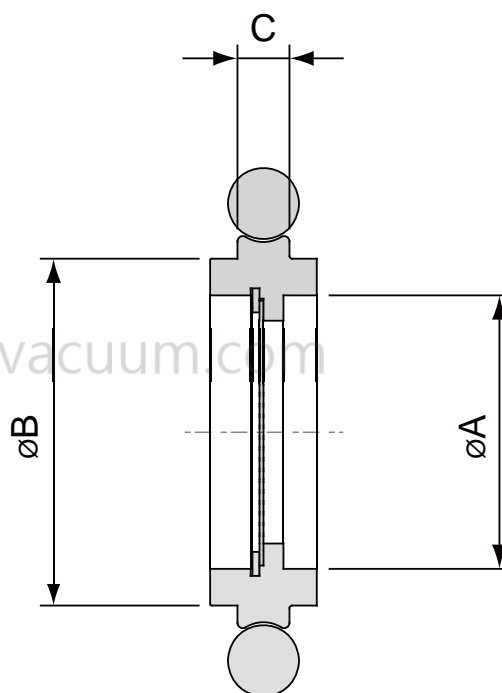

Model No.	Material C/R	Material O'Ring	Mesh/In ²	A	B	C	O'Ring Size	Parts No.
KF16M3CRVS	304 S.S.	Viton	900	12	17	3.9	AS-314	183105411
KF25M3CRVS	304 S.S.	Viton	900	20.5	26	3.9	AS-320	183106411
KF40M3CRVS	304 S.S.	Viton	900	35.8	41	3.9	AS-326	183108411
KF50M3CRVS	304 S.S.	Viton	900	46.3	52	3.9	AS-330	183109411
KF63M3CRVS	304 S.S.	Viton	900	60.5	69.6	3.9	AS-337	183110411
KF80M3CRVS	304 S.S.	Viton	900	73.6	82.6	3.9	AS-341	183111411
KF100M3CRVS	304 S.S.	Viton	900	91.8	101.6	3.9	AS-347	183112411
KF16M3CRNS	304 S.S.	NBR	900	12	17	3.9	AS-314	183305412
KF25M3CRNS	304 S.S.	NBR	900	20.5	26	3.9	AS-320	183306412
KF40M3CRNS	304 S.S.	NBR	900	35.8	41	3.9	AS-326	183308412
KF50M3CRNS	304 S.S.	NBR	900	46.3	52	3.9	AS-330	183309412
KF63M3CRNS	304 S.S.	NBR	900	60.5	69.6	3.9	AS-337	183310412
KF80M3CRNS	304 S.S.	NBR	900	73.6	82.6	3.9	AS-341	183311412
KF100M3CRNS	304 S.S.	NBR	900	91.8	101.6	3.9	AS-347	183312412

* O'Ring color for NBR material is black, brown is available upon request.

* O'Ring color for Viton material is brown, black is available upon request.

➔ KF Overpressure Ring

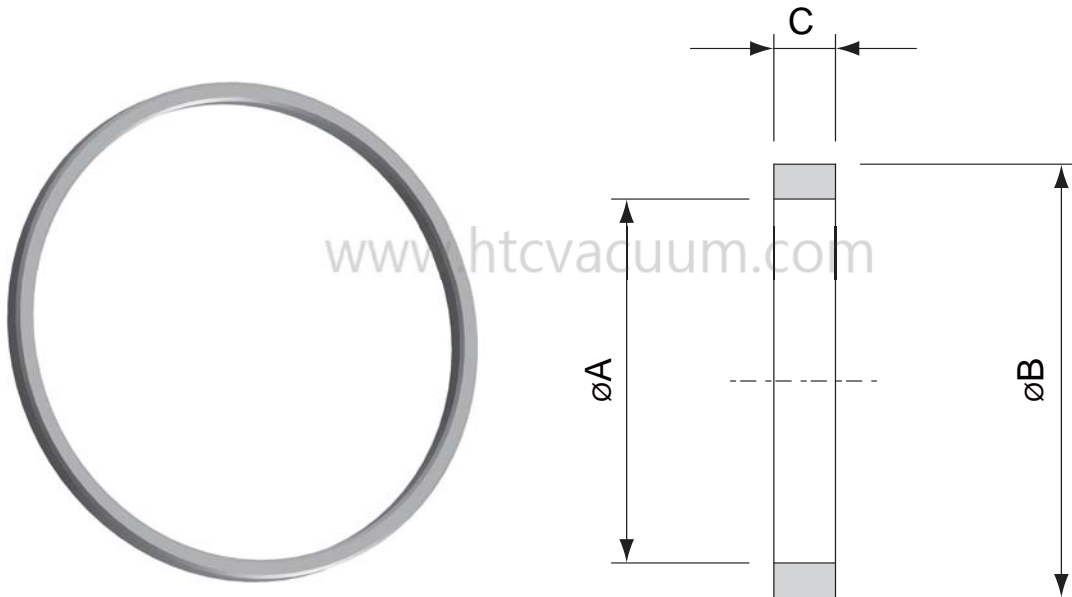

Model No.	Material	A	B	C	Parts No.
KF10OPR	304 S.S.	23.5	28	3.7	20000341
KF16OPR	304 S.S.	30.12	31.75	3.7	20000541
KF25OPR	304 S.S.	38.86	40.4	3.7	20000641
KF40OPR	304 S.S.	54	57.15	3.7	20000841
KF50OPR	304 S.S.	66.55	69.85	3.7	20000941
ISO63OPR	304 S.S.	87.1	93	3.9	20001041
ISO80OPR	304 S.S.	100.2	106	3.9	20001141
ISO100OPR	304 S.S.	119.3	125.3	3.9	20001241
ISO160OPR	304 S.S.	170.4	176.4	3.9	20001541